



25th Asia-Pacific Regional Scout Jamboree
28 December 2005 – 03 January 2006
Sattahip, Chonburi, Thailand

Important information for overseas participants

A. Arrival / Departure

The camp will open on 27 December 2005. The first meal to be served at the campsite will be dinner on 27 December. The Formal Opening Ceremony is in the afternoon of 28 December 2005. If your contingent arrives before 27 December 2005 you have two options:

- 1) You can avail of the Pre-Post Jamboree for which you shall make prior arrangement with the host Organization. The details are given under letter H of this document; or
- 2) You may opt to be accommodated in Vajiravudh Scout Camp, where participants will be expected to pay US\$7.00 per head a day for accommodation and food. (Vajiravudh Scout Camp is about two hours drive from Bangkok International Airport).

In both cases, the host organization will make transport arrangement for your contingent to the Jamboree Site on 27 December 2005.

On arrival, you will be received by Thai Scouts who will be in uniform. They will lead you to the "FAST TRACK" Immigration Counters, where the host organization made arrangements for fast immigration facilitation for Jamboree participants. Upon clearance with the Immigration and customs, contingents that are arriving before 27 December will be transported to their respective programme choice and those arriving on 27 December will be transported directly to the Jamboree Site.

The Closing Ceremony will be on 3 January and you must plan to leave the Jamboree Site on 4 January 2006. The last meal to be served at the campsite will be breakfast of 4 January 2006. In planning your travel please note that the travel time between the Jamboree Site and the airport is about two hours.

On arrival and departure, if in case you need help, the Thai Scouts are on stand-by at the VIP Room (CIP 8), which is located between Terminals 1 and 2 at the Bangkok International Airport.

For the transportation arrangement please return the arrival and departure form as early as possible.

B. Immigration

Fast Track counters will be available in December in both Terminal 1 and Terminal 2, at Bangkok International Airport for the arriving contingents. These Fast Track immigration counters will be open from 24 December 2005. Fast Track counters are immigration counters with the Thai Airways Logo and the word "FAST TRACK" on top of the counter.

C. Visa

Those countries which can obtain visa on-arrival needs to present an Official Letter of Invitation to the Immigration Counter together with the full list of participants who have arrived in the same flight and the visa fee requirement for visa-on-arrival will be waived. However, we regret to inform you, that countries, which require filing a visa application at the Thai Embassy/Consulate-General in their respective countries, prior to their visit to Thailand, may not be granted a gratis visa unless the concerned Embassy or High Commission may consider.

Countries who can obtain VISA ON ARRIVAL are: Bhutan, India, Maldives and Taiwan

To obtain the gratis VISA on Arrival, the following are the requirements:

- 1) Send an official letter to NSOT, asking for the letter of invitation. Please send the names of all the participants, passport number and Jamboree positions with your request letter.
- 2) NSOT will send an official letter of invitation to you.
- 3) When the contingent arrives at Bangkok International Airport, they must present the official letter of Invitation to the Immigration counter and the VISA fee on arrival will be waived.

Attached is the Group Visa on arrival form. This form should be attached in requesting for the letter of invitation.

Countries that do not require Visa and granted free entry to Thailand are: United States of America (USA), Australia, Austria, UK, Brunei, Cambodia, Chile, Denmark, Finland, France, Greece, Hong Kong, Indonesia, Italy, Japan, South Korea, Laos, Malaysia, Macau, Myanmar, New Zealand, Philippines, Singapore, Switzerland, and Vietnam.

Countries that must obtain Visa from embassy/consulate of Thailand in their own country before departure are: Bangladesh, Nepal, Pakistan, and Sri Lanka.

D. Duties and Customs

We are aware that contingents will be carrying a number of items for the camp. We would like to advise the contingent to travel in uniform so that you will not have problems at the customs and in the immigration. Special arrangements have been made with the Custom Authorities ONLY at the International Airport. Those contingents wishing to bring various items, it is advised that the contingent must bring all such items along with them so that there will be no custom duty levied. In case of very large stocks or large quantities, please inform NSOT in advance about the details of the materials as well as cargo – air/sea freight details in which the materials will be brought in and the general nature of the items.

A separate Customs Declaration Form will be sent in due course.

E. NSOs Participation in the Jamboree

All national Scout organizations who are sending a contingent to the Jamboree is also invited to participate and open an interactive stands in the following areas. Those NSOs wishing to take part in one or more of the following areas, are requested to write NSOT describing the project they have in mind and to indicate if they need any special arrangements at the activity area.

- 1) Global Development Village. A number of national Scout organization have addressed global issues through Scouting. We encourage these national Scout organizations to create a workshop on these promising practices.
- 2) Peace and Culture Circle. If your national Scout organization has accomplished peace initiatives or wish to showcase your culture, this is the best opportunity for you to do that in the Jamboree.
- 3) Free Time Activities. On 1 January, there will be a Kite Festival, which will be held along the coastline of Had Yao. National Scout Organizations are encourage to bring with them kites, which are unique from their country.

F. Exhibition Centre and Country Stands

Each national Scout organization will be provided with a country stand at the Exhibition Area. The size of each tent is 4m x 12m (dimension of the tent) – floor area and height is 48 sq.m. and each tent will be shared by two national Scout organizations.

Each country will be provided two Corrugated Plastic Boards (the dimensions are attached). If you need more, you may request the organizers for free. You can use double adhesive tape, scotch tape, and board pins to stick your exhibits. Attached is the display request form.

G. Token of Appreciation to NSOT

A reception for all the Contingent Head will be organized and this will be an opportunity for the contingents to give a token of appreciation to the National Scout Organization of Thailand (NSOT), as the host organization

H. Pre and Post Jamboree Programme

We would like to inform national Scout organizations that Home Hospitality or home stay in a Thai Family will not be available for this Jamboree. If you want to avail of the pre-Jamboree or post-Jamboree Programme, you will need to pay US\$15.00 per head/night. To join this programme pre-arrangements MUST be made before the arrival of the contingents and should pay for the programme before the start of the programme.

This fee will cover accommodation, transportation and three meals a day. This will also include transportation to interesting places within 150-kilometer radius of where the person (or the contingent) is accommodated. This fee does not include entrance fees to museum, parks, etc.

Please inform the host organization of your request on the specific area you want to visit or if you have a prepared programme already please send it in advanced. Attached is the Pre – Post Jamboree Programme Form

I. Visitors

Visitor's can visit the campsite starting 29 December 2005 until 3 January 2006. Visitors (parents, teachers, Scout Leaders, etc.) who wish to observe the Jamboree, can visit the Jamboree as DAY VISITORS and are required to pay an entrance fee of USD1.00 per head/per visit. Please note that the Jamboree Site can only accommodate 1,500 persons a day (on first-come-first-serve basis). Visiting time is as follows:

Morningfrom 0930H to 1200H

Afternoonfrom 1330H to 1600H

J. Guests

All key national Scout leaders, such as President/Chairman of the Scout Councils, Members of the various APR Committees and Sub Committees, Chief Commissioners and International Commissioners, as well as selected guests, are welcome to attend the Opening Ceremony and for few days of the 25th Asia-Pacific Regional Scout Jamboree.

Guests, are expected to pay a registration fee of US\$100.00 for few days of their stay during the Jamboree. The fee will include, local transport to and from the airport, accommodation at JamHotel (staff tents) and some staff meal coupons. If they wish to stay in a hotel near the Jamboree Site, pre-hotel booking MUST be made through the International Commissioner, Mr. Sutham Phanthusak, the rate for the hotel accommodation is US\$50.00 per day including breakfast in a three star hotel. If guests are staying in the hotel booked by the host country, then transport between the Jamboree Site and the hotel will be made on scheduled trip.

K. Closing Ceremony (Sub-Camp Presentation)

At the sub-camp level, contingents will make a cultural presentation. The best presentation at the sub-camp level will be invited to present at the Closing Ceremony. There will only be 12 slots for overseas contingents in the Closing Ceremony – one from each sub-camp.

L. Patrol/Troop Equipment

Attached is the list of what to bring and what the host country will provide.

M. Troop Organization

Troop Leaders are required to stay at the Sub-Camp with the participants. Contingent Heads and Staff will be provided tent accommodation at the JamHotel.

Please ensure that you have submitted the Troop Registration form.

N. JamHotel/Accommodation

All Contingent Heads and other Contingent Staff are required to stay at the JamHotel. There will be no tent rent for the JamHotel, as long as they have paid the Jamboree registration fee. Generally, one tent in the Jamhotel can accommodate 2 persons. Except for the Contingent Head, who will be on single tent, two people will share one tent.

When you arrive in the JamHotel, these staff tents are pitched and ready for you. Bedding (pillow with pillowcases and mattress with bed sheet) are provided.

O. Avian (Bird) Flu Prevention

There is no announcement even from the World Health Organization (WHO) to indicate that the bird flu virus is spread from human to human. It is ONLY from bird to human and the Health Authorities of Chonburi area is guaranteeing that Jamboree area is free from bird flu and according to the Government sources Chonburi is not a risk area as well. This is the information given by the Health Authorities in Thailand.

P. Bank charges

Contingent will have to shoulder the bank charges imposed by your national bank when transferring their money. NSOT is expected to received the net amount due for the camp registration fee therefore, please send the copy of bank transfer receipt after the money transfer.

Q. IST

Members of the International Service Team (IST) will stay at the IST Sub-Camp. Overseas IST's need not to bring their tents, as it is included in the registration fee. All IST should be inside the camp on 25 December 2005. Orientation will be on 26 December at 1000H.

S. Miscellaneous

For more information, please email: info@aprjam25.org with a copy to nsot@scoutthand.org and to the International Commissioner, Mr. Sutham Phanthusak at sutham@woodland-resort.com.

Attached are the following Forms:

- 1) Group Visa On-Arrival Form
- 2) Display Panel Reservation Form
- 3) Jamboree Hospitality Programme Form
- 4) Items to bring to the Jamboree



25th Asia-Pacific Regional Scout Jamboree
 28 December 2005 – 03 January 2006
 Sattahip, Chonburi, Thailand

Display Panel Reservation Form

Name of Association

A free exhibition stand (two panels) will be provided to each association/ country.

One display panel size 1.2 m x 1.2 m (1.2 m width and 2 m height)

- We would like to request the space for a display of our Organization**
- We do not want to reserve a display space**

If you would like to have more panels, how many more would you need?

- 3 panels
- 4 panels
- 5 panels
- 6 panels
- _____ panels

Remarks:

.....

.....

.....

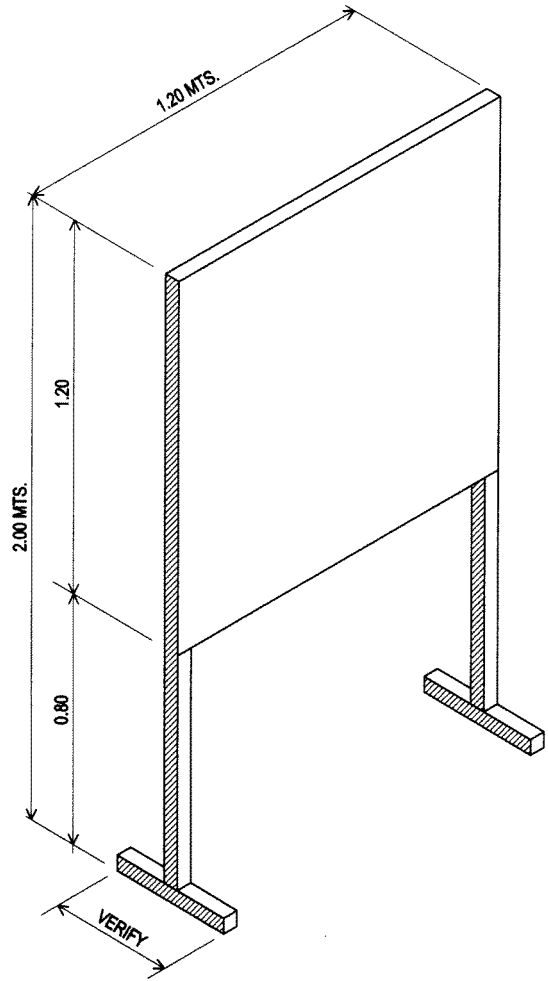

Signature: _____

Name of Responsible Person:

Position:

Date Sent:

(dd/mm/yy)



25th Asia-Pacific Regional Scout Jamboree

28 December 2005 – 03 January 2006

Sattahip, Chonburi, Thailand

PRE – POST JAMBOREE PROGRAMME FORM										
Country			National Scout Organization							
PRE-JAMBOREE PROGRAMME			POST-JAMBOREE PROGRAMME							
From		To		From						
Arrival Date	Time	Flight No.		Departure Date	Time					
				Flight No.						
SUMMARY OF PARTICIPANTS			PROGRAMME FEE							
Scouts (Total)	Male	Female		<p>For this Pre and Post Jamboree Hospitality Programme, all contingents will be looked after by various School authorities from the Bangkok Area. Over 31 schools are taking part in providing the Pre/Post Jamboree Hospitality Programme to the participants. You will be accommodated in school dormitories</p> <p>Each contingent will be assigned to a particular school authority and for those contingents with large numbers, they will be distributed into two to three schools. The school who will host you under this programme will meet you and/or send you off at the airport, as the case maybe.</p> <p>There will be a cost which each Contingent are expected to pay at the rate of US\$15.00 per head a day. This fee includes food and accommodation, and sightseeing, which will based on the interest of the respective Contingents.</p> <p>Sightseeing will be undertaken within a radius of 150 km from Bangkok City. The daily package price for this programme does not include entrance fees to specific tourist sites, if there is such a fee. And in such cases, the entrance fees must be paid directly by those participants visiting such sites.</p>						
Leaders (Total)	Male	Female								
IST (Total)	Male	Female								
Grand Total	Total	Total								
			<table border="1"> <tr> <td>Total No. of Persons</td> <td>Multiply by</td> <td>Total amount Due</td> </tr> <tr> <td></td> <td>US\$15.00</td> <td></td> </tr> </table>			Total No. of Persons	Multiply by	Total amount Due		US\$15.00
Total No. of Persons	Multiply by	Total amount Due								
	US\$15.00									
PREFERENCE FOR PLACES TO VISIT										
1.										
2.										
3.										
4.										
5.										
ENDORSEMENT			MODE OF PAYMENT							
Name of the National Scout Organization			<input type="checkbox"/> Telegraphic Transfer							
Name of person authorizing this application			<input type="checkbox"/> Check							
Position of person authorizing this application			<input type="checkbox"/> Will be paid on arrival							
Date of application			<input type="checkbox"/> Others, please specify _____							
Signature of person authorizing this application										

IMPORTANT

All Pre and Post Jamboree Hospitality Programme is coordinated by Mr. JARUK SRILERT (mobile number is +66 7 / 2528004). Please send this reply slip to him at info@aprijam25.org with a copy to nsot@scoutthand.org and to the International Commissioner, Mr. Sutham Phanthusak at sutham@woodland-resort.com.

/ypc



25th Asia-Pacific Regional Scout Jamboree
28 December 2005 – 03 January 2006
Sattahip, Chonburi, Thailand

Items to bring to the Jamboree

1) Personal Kit

All participants should bring their own personal belonging and some necessary camp equipment such as:

- Rucksack / small rucksack for excursion and hike
- Sleeping bag / sleeping pad or mattress
- Scout uniform
- National costume for New Year festival and Peace Day on 1 January 2006.
- Clothing: short / long trousers, t-shirts, sweater, swimming suit, socks, towels etc.
- Sport shoes / walking shoes
- Washing things: soap, shampoo, detergent
- Mess kits: plate, mug, folk/spoon, drinking bottle
- Electric torch / compass
- Sun Cream , sun glass, sun hat
- Protection of insects, mosquitoes
- Notebook, pen, pencil etc.

2) Country / Contingent

- Two (2) Association flags
- Traditional food or dessert for New Year and Peace Day celebration on 1 January 2006
- Association / National Display at Exhibition Area of the campsite. Two panels (size 1.2 x1.2 x 1.8 m.) with 1 table and 2 chairs will be provided for each country / association. (Please kindly inform and request NSO Thailand If you need more.)

Note: Please be informed that for the regulations of customs on big packs of food will not be allowed free of tax at the custom declaration. It should be separated in small packs and carried as scout personal belonging. (Rice will not allowed to bring in to Thailand).

Camp equipment the Jamboree will provide

Each patrol will receive these camp equipment from their sub-camp:

1. 2 Tents (size for 6 persons) + 1 tent (size for 2 persons)
2. bamboo stick for camp decoration 5 pieces
3. fly sheet 1 piece
4. straw rope 1 roll
5. water tub 1 tub
6. garbage bags
7. tissue paper rolls
8. drinking water 1 tank / day
9. drinking water 10 bottles / day
10. gas stove 1 set
11. cooking utensils 1 set
 - a. 3 pots
 - b. 10 plates
 - c. 10 set of folk & spoon
 - d. 5 small bowls
 - e. 5 big bowls
 - f. 1 pan
 - g. 1 frying flipper
 - h. 1 kettle
 - i. 3 knives
 - j. 1 water jar
 - k. 10 water glasses
 - l. 1 water bowl
 - m. 1 cutting plate
 - n. 1 bottle of dish soap + 1 sponge sheet
 - o. 1 piece of dish cloth

The camp equipment which will be available to all patrol at each sub-camp are the following:

1. saw
2. shovel
3. hammer
4. digging tool
5. spade
6. rubbish sweeper